

## Active Sampling AirCore (ASAC) for Regional Trace Gas Sampling Surveys

T. Newberger<sup>1</sup>, C. Sweeney<sup>1</sup>, A. Karion<sup>1</sup>, D. Gunther<sup>1</sup>, H. Chen<sup>2</sup>, K. Loving<sup>1</sup>, S. Wolter<sup>1</sup> and P. Tans<sup>2</sup>

<sup>1</sup>Cooperative Institute for Research in Environmental Sciences, University of Colorado, Boulder, CO 80309; 303-497-6861, E-mail: Tim.Newberger@noaa.gov

<sup>2</sup>NOAA Earth System Research Laboratory, Boulder, CO 80305

The NOAA ESRL GMD Carbon Cycle and Greenhouse Gases Group has developed and tested a prototype trace gas sampling system that utilizes a SulfiNert™-treated (Restek Inc.) stainless steel tube (AirCore) to store continuously sampled air during horizontal surveys conducted by small Unmanned Aircraft Systems (UAS) such as the Scan Eagle. A trace gas analyzer such as a multispecies Cavity Ring Down Spectroscopic gas analyzer is used post flight to analyze the stored gas in the AirCore. The ASAC for UAS deployment (Figure 1) will have a total weight of approximately 6 kg. The 4.1kg AirCore tubing is the largest component in the ASAC system. The tubing outside diameter (1/8"), length (213 m), and wall thickness (0.01"), were chosen to maximize sampling resolution while remaining within the weight specifications for a Scan Eagle payload. Other hardware components in the system include a pump, a filter, a pressure-control system, a gas dryer, a mass-flow control device (a critical orifice), a data acquisition board, and a data logging system. We estimate the weight of these components to be close to 1.9 kg. We expect to maintain the gas pressure inside the AirCore tubing at two atmospheres to maximize total sample volume while sampling at 10 standard cubic centimeters per minute. Accounting for diffusive mixing of the sample during flight and post-flight analysis, approximately 240 discrete atmospheric samples over a 4-hour flight can be resolved. Assuming a 60-knot speed for the UAS, a distance of approximately 430 km will be traversed during a 4-hour deployment, providing an average sampling resolution of 1.7 km. Here we describe this sampling system and present results from both flight and driving tests.

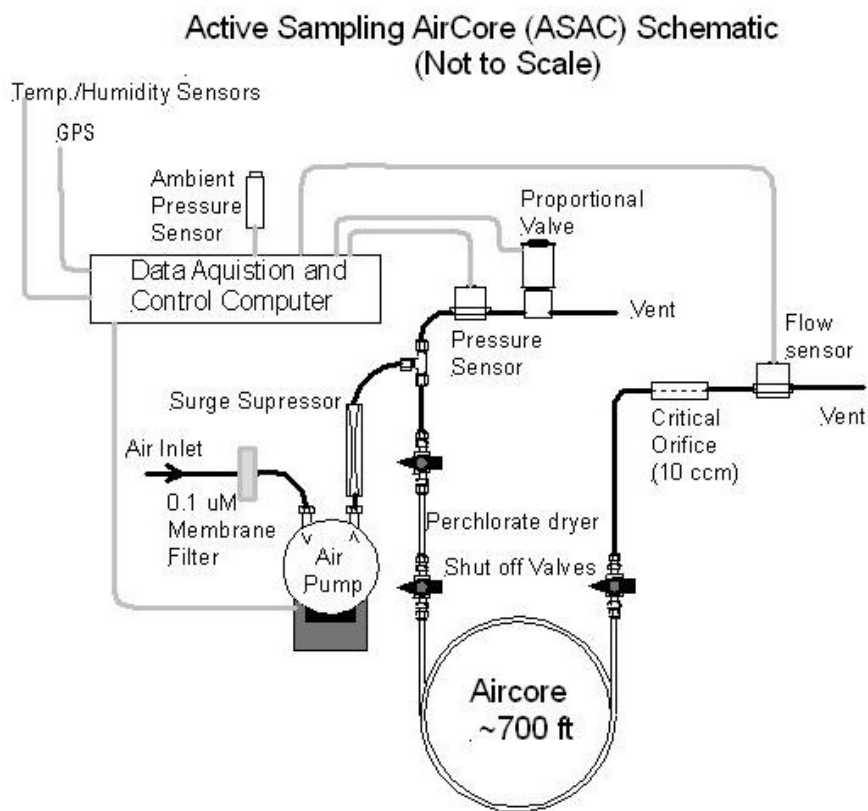

**Figure 1.** Diagram of ASAC system for unmanned aircraft system deployment.